

1.0 Scope

This test method determines specific load values to establish a performance duty level of the wall cabinet assembled unit (henceforth referred to as “test specimen”). These load values do not suggest service loads nor shall they be construed as suggesting normal casework usage loads.

2.0 Applicable Documents

- 2.1 ANSI/AWI 0641 - Architectural Wood Casework (latest edition)
- 2.2 AWI Standard for Manufactured Wood Casework (latest edition)
- 2.3 AWI Standard for Specialty Casework (latest edition)

3.0 Significance and Use

Test data will provide useful information for architects, design professionals, and manufacturers in making judgments on the ability of an architectural casework assembly to maintain serviceability under actual operating conditions. This test method is not intended to determine serviceability of hardware components.

This test method will not determine the useful life of architectural casework in service as a result of the data obtained during the test. It will, however, indicate the integrity of joinery and materials under test conditions.

4.0 Test Fixture

4.1 Main Testing Fixture

The main testing fixture is constructed as shown in Figure 55. The test fixture is constructed of steel, wood, and other materials as indicated. The test frame must provide support for the fully loaded test specimens, elevating them no less than 229 mm [9"] above finished floor.

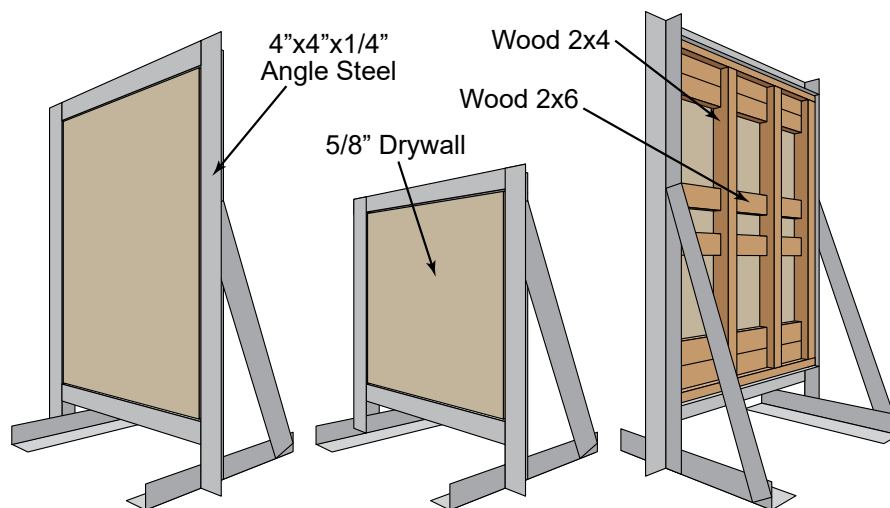

Figure 55

5.0 Test Specimen

Any specific instructions for mounting casework to the test fixture shall be included in the submittal package. Any specific hardware to be used in mounting casework to the testing fixture shall be delivered with test specimen.

5.1 Test Specimen Technical Drawings

5.1.1 Drawing Requirements

Drawings shall be submitted as A3 [297 mm × 420 mm] or Tabloid [11" × 17"] size documents, formatted in landscape orientation.

All drawings shall be rendered in black and white.

Text markings shall be an easily legible font in uppercase text and appropriately scaled to viewport.

Line weight in drawings shall be plotted in a clear and legible line weight.

All measurement dimensions shall be expressed in both Metric and U.S. Customary System units of measure.

5.1.2 Drawing Formats

All information in the submittal's title block shall be complete and in accordance with specimen submittal drawing instructions.

One set of digital test specimen drawings in PDF file format shall be attached to each test application form submitted.

One set of printed drawings on A3 [297 mm × 420 mm] or Tabloid [11" × 17"] size paper shall be attached to each test specimen. Paper drawings shall be inserted into a clear plastic document protector sleeve and secured with adhesive tape to the specimen's face.

5.1.3 Drawing Information Conveyance

Drawings shall convey joinery means and methods of intersecting casework components, as well as relevant machining dimensions.

Drawing shall include plan view, front elevation, side elevation, rear elevation, vertical section at each change in elevation, horizontal section at each change in elevation, auxiliary sections as required indicating faster locations, full scale details as required indicating construction method and fasteners.

For clarity, full scale details shall be included as supplemental illustrations of joinery, machining, fasteners, and hardware.

The location of all hardware, connectors, fasteners, and spacing shall be illustrated. Identification notes for each hardware item shall include nomenclature type, size, material, model number, and manufacturer, as applicable.

The location of each type of adhesive application shall be illustrated in the drawing details. Identification notes for each adhesive item type shall include manufacturer, adhesive nomenclature type, and trade brand name, as applicable.

5.2 Test Specimen Assembly

5.2.1 Specimen Materials

The test specimen may be constructed of any core material and joinery combination, provided that the material(s), fasteners, spacing, and machining operation(s) are fully documented in test specimen technical drawings. Product core requiring additional face or back material/overlay, that exceeds the tested material as required by a project's contract documents, are subject to duty level findings of this test specimen.

5.2.2 Specimen Size Requirements

The test specimen shall be a complete wall cabinet assembly with overall outside dimensions of 914 mm [36"] (± 1.6 mm [.063"]) width \times 305 mm [12"] (± 1.6 mm [.063"]) depth (including faces of doors) \times 914 mm [36"] (± 1.6 mm [.063"]) height.

The test specimen shall include, at minimum, the following assembly components:

- One left vertical side component
- One right vertical side component
- One top horizontal component
- One bottom horizontal component
- One horizontal adjustable shelf component, adjustable in the horizontal plane and placed at the interior's vertical midpoint (± 25.4 mm [1"])
- One vertical back component
- Two vertical hinged doors

5.2.3 Specimen Exposed Core Requirements

Test specimens shall have at least four areas of exposed core material measuring no less than 9.5 mm [.375"] \times 38.1 mm [1.500"] in the following locations to facilitate testing of core moisture content as described in Section 6.2.5 of this document.

- The rear edge of the adjustable shelf component
- The right vertical side component
- The left vertical side component
- A door component

5.2.4 Method of Installation

Method of installation shall be included as a document separate from the test specimen drawings. Method of installation shall include installation step by step instructions, and fastener details, and spacing. Manufacturer/supplier may defer to the AWI Casework Installation Guidelines available for download at <http://www.awinet.org/standards>

6.0 Conditioning

6.1 Pre-Test Acclimation

Test specimens shall be acclimated in the test facility environment for no less than 72 hours after date of arrival and under conditions in compliance with requirements as established in AWI 200 - Care and Storage (latest edition).

6.2 Test Environment

The test facility shall maintain continuous monitoring and an archival record of the facility's indoor environmental conditions at a minimum of one hour intervals, including:

- Temperature
- Relative humidity

6.2.1 Environmental Condition Log

The official date and time of the Environmental Condition Log (ECL) begins upon receipt of the test specimen and is continuous throughout the acclimation and testing procedures. At the conclusion of the final test procedures, the test specimen's ECL shall cease and be closed with a final environmental close-out log entry.

6.2.2 Test Specimen Moisture Content Log

Each test specimen will undergo internal moisture content measurement readings which will be recorded in the specimen's Moisture Content Log (MCL) as follows:

- Upon receipt of the test specimen at the test facility
- At the conclusion of the 72-hour acclimation period
- Within four hours of the completion of the testing process

6.2.3 Measurement Devices - Moisture Content

Wood moisture percentage readings shall be obtained with a pin type moisture meter.

6.2.4 Measurement Points - Moisture Content

Moisture readings shall be obtained and recorded as follows:

Four probe points consisting of exposed core locations as described in Section 5.2.3 of this document shall be utilized for attaining moisture content measurements. The average of these four readings shall constitute one single average moisture content log entry of record.

Average Moisture % = Sum [Reading 1 Left Side % + Reading 2 Door % + Reading 3 Right Side % + Reading 4 Shelf %] divided by 4.

7.0 Testing Procedure

7.1 Specifications - Test Fixture

The test fixture used shall be as described in **4.0 Test Fixture**.

7.2 Test Specimen Mounting

The test specimen shall be centered laterally on the test fixture with no less than 152.4 mm [6"] of unobstructed surface from the test specimen's horizontal bottom component (Figure 56-C), no less than 305 mm [12"] of unobstructed surface from the test specimen's horizontal top component (Figure 56-A), and no less than 152.4 mm [6"] of unobstructed surface on each side (Figure 56-B). Install test

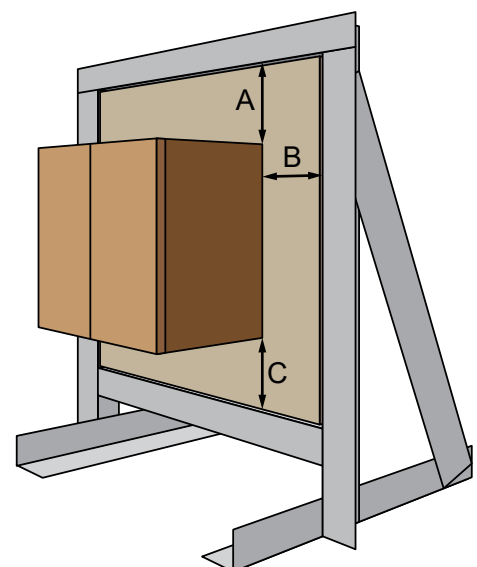

Figure 56

Testing Methods, WC-1 Assembled Unit Test

specimen plumb and level within 1.6 mm [.063"] over 9.7 meters [32'] in both vertical and horizontal axis.

7.3 Test Specimen Installation

Test specimen shall be installed according to manufacturer/supplier's supplied installation instructions. In absence of manufacturer/supplier's documented instructions, installation may defer to the AWI Casework Installation Guidelines at the approval of the manufacturer/supplier, available for download at <http://www.awinet.org/standards>

7.4 Anchoring Test Specimen to the Test Fixture

Test Specimen shall be anchored to the test fixture according to the manufacturer/supplier's documented installation instructions.

7.5 Pre-Test Specimen Set-Up

Place the test specimen's adjustable shelf (Figure 59-D) +/- 25.4 mm [1"] from the interior's vertical center point within the shelf area of the cabinet. Follow the adjustable shelf placement/anchoring details and instructions as specified by the test specimen's drawings.

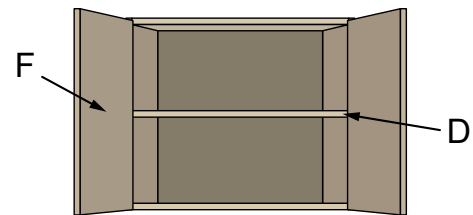

Figure 59

Test specimen's doors (Figure 59-F) shall be attached, adjusted (where adjustment is available), and verified for proper swing and operation. If required, adjust door alignment, gaps, flushness, and instructions as specified by the test specimen's drawings.

During the pre-test set up, any circumstances that prevent the test specimen from achieving compliance to the specifications indicated by the test specimen's drawings shall be cause to halt procedure and issue a Test Specimen Nonconformity Notice Report. No further testing may proceed with the Test Specimen until such time as the Nonconformity is resolved.

7.6 Test Specimen Tolerance Verification/ Measurement Devices

All measurement instruments used within this testing methodology shall be manufactured by a certified organization and shall be metrologically traceable to the International System of Measurement (SI). All measurement devices shall be calibrated in accordance with manufacturer/supplier's documented instructions prior to obtaining measurements. Calibration of all devices shall be recorded in a calibration log.

7.6.1 Tapered Thickness Gauge, Tapered Leaves, .03 to 0.5 mm Thickness

Used to measure gaps present in cabinet components after testing.

7.6.2 Metric Thickness Gauge

Used to measure gaps present in cabinet components prior to testing.

7.6.3 Digital Caliper

Used to measure reveal gaps between doors and components, as well as thicknesses of core, shelf, and door panel materials prior to testing.

Testing Methods, WC-1 Assembled Unit Test

7.6.4 Metric and U.S. Customary Pocket Tape

Used to measure overall dimensions and squareness of the test specimen prior to testing. Used to measure length of door components and length of gaps between cabinet components prior to testing.

7.6.5 Vernier Depth Gauge

Used to measure flushness of cabinet component joints prior to testing.

7.6.6 Level Measurement Device

Used to measure levelness of test specimen prior to testing.

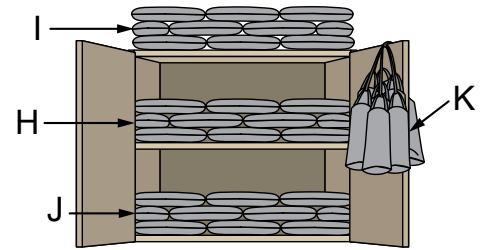

Figure 61

7.7 Measurement Process

Before mounting, initial measurements of all tolerances for gaps, flushness, and operation of all functional elements shall be measured, verified, and recorded on the Test Specimen Record Log.

7.8 Load Testing Process

7.8.1 Test Weight Options and Specifications

Lead or steel shot fabric bags shall be verified and calibrated. Exact weight shall be noted on bag's identification tag.

If substituted for lead shot fabric bags, metal ingot bars shall not exceed 292.1 mm [11.5"] in length. Each ingot's weight shall be verified and marked on the ingot's identification tag face.

7.8.2 AWI Casework Load Table

Performance Duty Level	Assembled Unit Load	Typical Application
Duty Level 1	35 lb./sq. ft.	Light Commercial
Duty Level 2	50 lb./sq. ft.	Commercial
Duty Level 3	65 lb./sq. ft.	Institutional
Duty Level 4	85 lb./sq. ft.	Laboratory

CLT-1

7.8.3 Test Steps and Test Process Step 1:

Using a verified and calibrated combination of weights, beginning at the center line of the component, evenly and incrementally introduce load to the bottom horizontal component (Figure 61-J).

Target Distributed Load:

Duty Level 1	Duty Level 2	Duty Level 3	Duty Level 4
35 lb./sq. ft.	50 lb./sq. ft.	65 lb./sq. ft.	85 lb./sq. ft.

TDPLT-1

Testing Methods, WC-1 Assembled Unit Test

7.8.4 Test Steps and Test Process Step 2:

Using a verified and calibrated combination of weights, beginning at the center line of the component, evenly and incrementally introduce load to the adjustable shelf horizontal component (Figure 61-H).

Target Distributed Load:

Duty Level 1	Duty Level 2	Duty Level 3	Duty Level 4
35 lb/sq. ft.	50 lb/sq. ft.	65 lb/sq. ft.	85 lb/sq. ft.

TDPLT-2

7.8.5 Test Steps and Test Process Step 3:

Using a verified and calibrated combination of weights, beginning at the center line of the component, evenly and incrementally introduce load to the top horizontal component (Figure 61-I).

Target Distributed Load:

Duty Level 1	Duty Level 2	Duty Level 3	Duty Level 4
35 lb/sq. ft.	50 lb/sq. ft.	65 lb/sq. ft.	85 lb/sq. ft.

TDPLT-3

7.8.6 Test Steps and Test Process Step 4:

Using a verified and calibrated combination of weights, evenly introduce load to each door component 101.6 mm [4"] from outside edge of door components (Figure 61-K).

Target Distributed Load:

Duty Level 1	Duty Level 2	Duty Level 3	Duty Level 4
120 lb. each			

TDPLT-4

7.8.7 Test Steps and Test Process Step 5:

Log date/time as the start of the test duration period.

7.8.8 Determining Point of Failure

Product failure is defined as a loss of serviceability of the unit due to cracking or breaking of unit components, joinery separation from specimen body, loss of serviceability of doors, or separation of components that will not return to their original state or placement within the unit.

Point of failure is defined as the moment when a failure is observed or recorded.

8.0 Record of Test Result

8.1 Measurement Process

Before mounting, measurements of all tolerances for gaps, flushness, and operation of all functional elements shall be measured, verified, and recorded on the Test Specimen Record Log.

Following 24 hours of loading, remove all load from the sample case. All tolerances for gaps, flushness, and operation of all functional elements shall be measured, verified, and recorded on the test specimen record log.

Test specimens shall be measured prior to and after testing to determine squareness of right top to left bottom (diag.) and left top to right bottom (diag.); flushness of bottom right, bottom left, top right, top left; gap width and length of bottom right, bottom left, top right, top left, back; and door to door reveal gap.

Right and left door operation shall be tested.

8.2 Nonconformities

All nonconformities shall be identified and deviations recorded.

Deviation measurements greater than the tolerances allowed in the referenced standard shall be deemed as a failure to meet the structural performance requirements of this test.

9.0 Test Report

The AWI Performance Quality Test Report is the official test report for standard compliance. The results of these findings will be valid for one (1) calendar year from date of report. Conformance to tested methodology is subject to verification to ensure integrity of the product is maintained. Noncompliant verification may result in a suspension of the Test Report. The following information must be submitted to complete the Performance Quality Test Report:

9.1 Test Applicant

- Legal Business Name, Street Address, City, State, ZIP Code and Phone Number

9.2 Independent Testing Laboratory (ITL)

- Legal Business Name, Street Address, City, State, ZIP Code
- Authorizing Signee's Name, Title, Phone, Email
- Testing Laboratory Service Order #, Testing Laboratory Customer ID, Testing Laboratory Battery #, Specimen #
- Date of Specimen Receipt
- Date of Test Performed

9.3 Target Duty Level Declaration

9.4 Test Documentation

- All information required for this test methodology

9.5 Material

- Documentation of component material, thickness and grade

9.6 Specimen Dimensions

9.7 Actual Test Load Weight

9.8 Notes, Observations, and Photographs of Specimen

- Before, during, and after test

9.9 Equipment Used to Execute Test

- Calibration documentation (when required)

9.10 Signed Statement of Specimen Affirmation

9.11 Signed Statement of Test Process Verification

9.12 Specimen Drawings

- Plan View 1"=1'-0" or 1 ½"=1'-0"
- Front Elevation 1"=1'-0" or 1 ½"=1'-0"
- Side Elevation 1"=1'-0" or 1 ½"=1'-0"
- Back Elevation 1"=1'-0" or 1 ½"=1'-0"
- Vertical Section 1 ½"=1'-0"
(through any change of views, including semi-exposed & concealed dividers)
- Horizontal Section 1 ½"=1'-0"
(through any change of views, including semi-exposed & concealed dividers)
- Joinery details/spacing Half or Full Scale
- Adhesives used

9.13 Test Specimen's Installation Instructions

9.14 Test Specimen's Moisture Humidity Log Record

- Acclimation
- Pre-Test
- Post-Test

9.15 Declaration of Test Methodology Used for This Test

9.16 Signed Statement of Results

No part of this publication shall be reproduced in any form, in an electronic retrieval system or otherwise, without the prior written permission of the publisher.



Architectural Woodwork Institute
46179 Westlake Drive, Suite 120, Potomac Falls, VA 20165
Phone: 571-323-3636, Fax: 571-323-3630
www.awinet.org