

## MATERIAL NOTES

THE FOLLOWING ENGINEERING DRAWINGS ILLUSTRATE THE TESTED ENGINEERING OF DOWELED CONSTRUCTION BASE CABINETS USING GRADE 130 MDF CORE TFL (2-SIDE), M-2 PARTICLEBOARD CORE TFL (2-SIDE), AND VENEER CORE PLYWOOD. THESE DRAWINGS DO NOT INDICATE COMPLIANCE WITH AWI STANDARDS. MANUFACTURERS SHALL ACQUIRE AN OFFICIAL AWI TEST REPORT IN ORDER TO INDICATE COMPLIANCE.

## ENGINEERING NOTES

- CABINET SIZE AND CONFIGURATION MAY BE ALTERED AS LONG AS JOINERY, SPACING, AND LOCATION REQUIREMENTS ARE FOLLOWED.
- ALL JOINERY SHALL MEET THE TOLERANCES OF AWI STANDARDS.
- DOWELS SHALL BE 8MM X 30MM.
- CONSTRUCTION ILLUSTRATED HEREIN IS CONFORMING FOR ALL FRAMELESS DOOR AND DRAWER OVERLAYS.
- STRETCHERS AND NAILERS MAY ALLOW FOR A TOLERANCE OF +/- 1.6MM [ $\frac{1}{16}$ ] IN THE 127.00MM [5"] WIDTH.

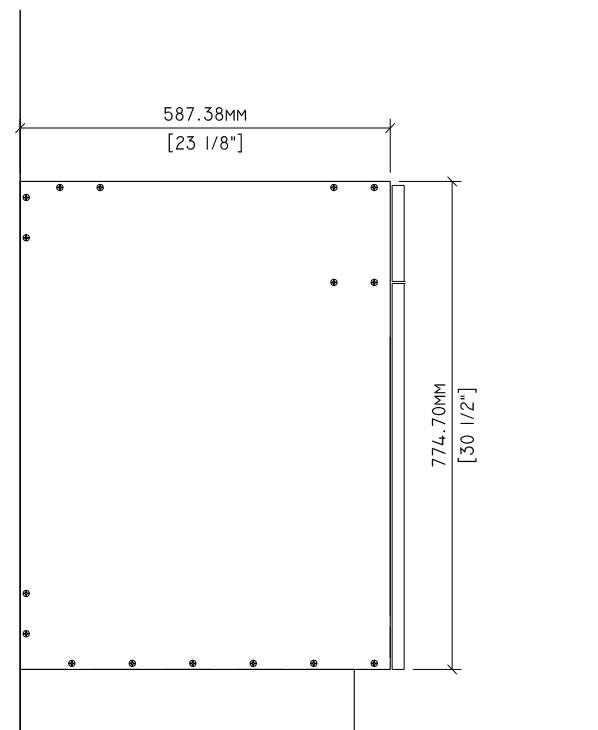
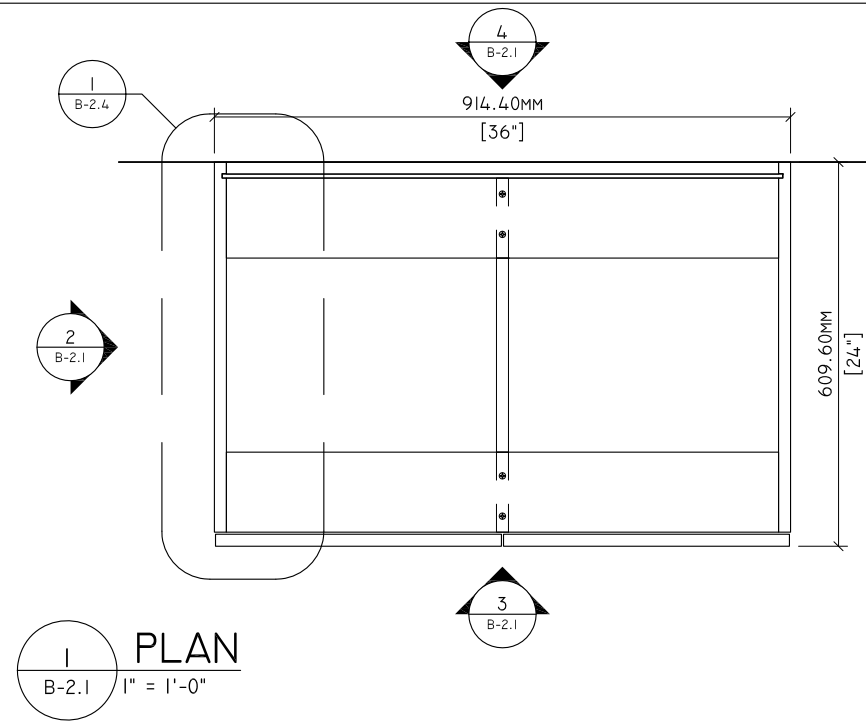

2 B-2.1 SIDE ELEVATION  
1" = 1'-0"

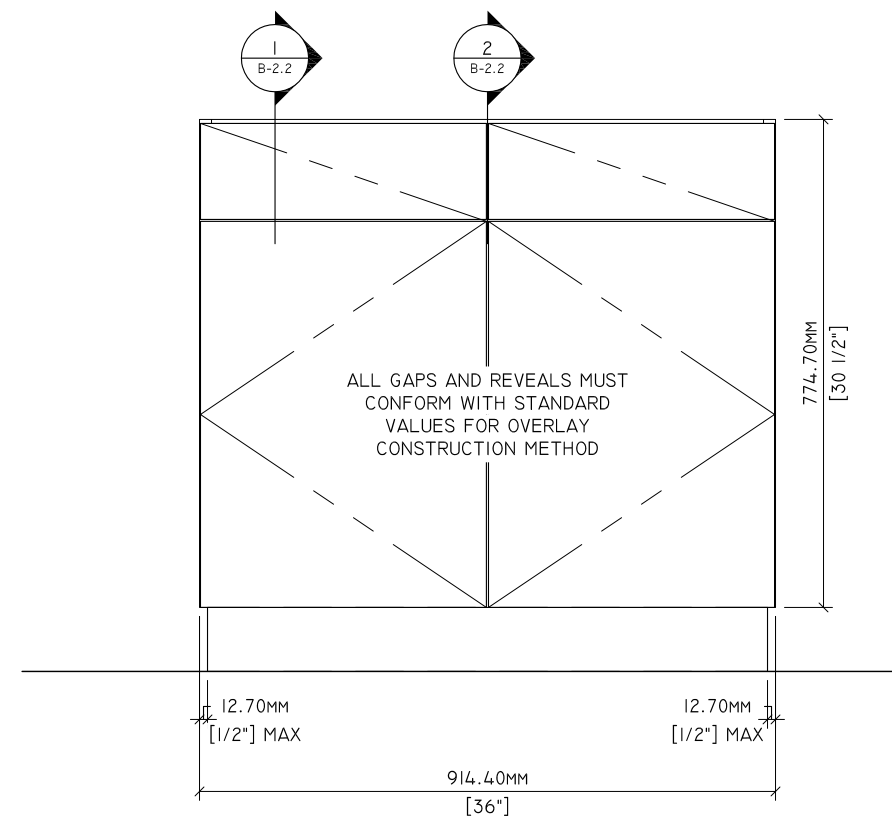

3 B-2.1 ELEVATION  
1" = 1'-0"

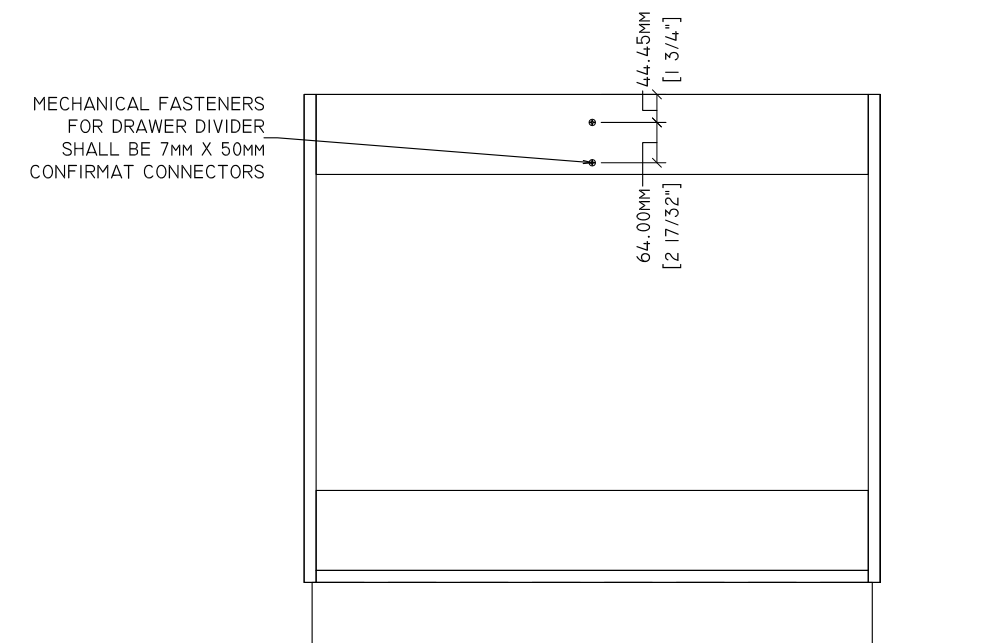

4 B-2.1 BACK ELEVATION  
1" = 1'-0"

Drawn By:		REVISIONS		SPECIMEN DWG. NO.:
HD		△	-	B-2.1
Reviewed By:	-	△	-	JOINERY METHOD NO.: 7mm X 50mm CONFIRMAT
Revised By:	HKM	△	7/7/2020	SPECIMEN MATERIAL: MDF, PB, VC
Revised By:	HKM	△	7/9/2021	BATCH QUANTITY: -
Approved By:	-	△	-	SCALE: AS NOTED

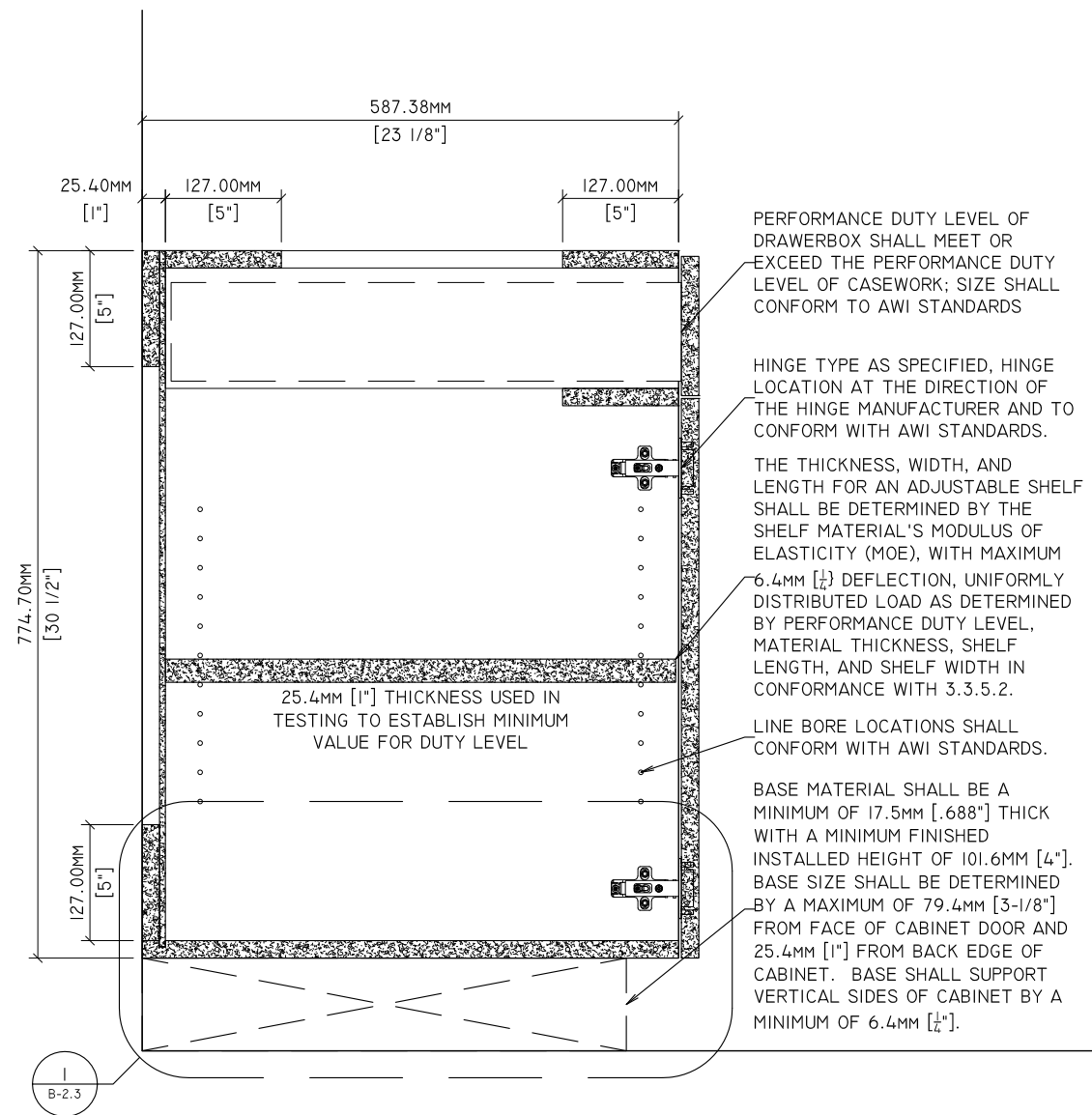

1 SECTION  
B-2.2 1-1/2" = 1'-0"

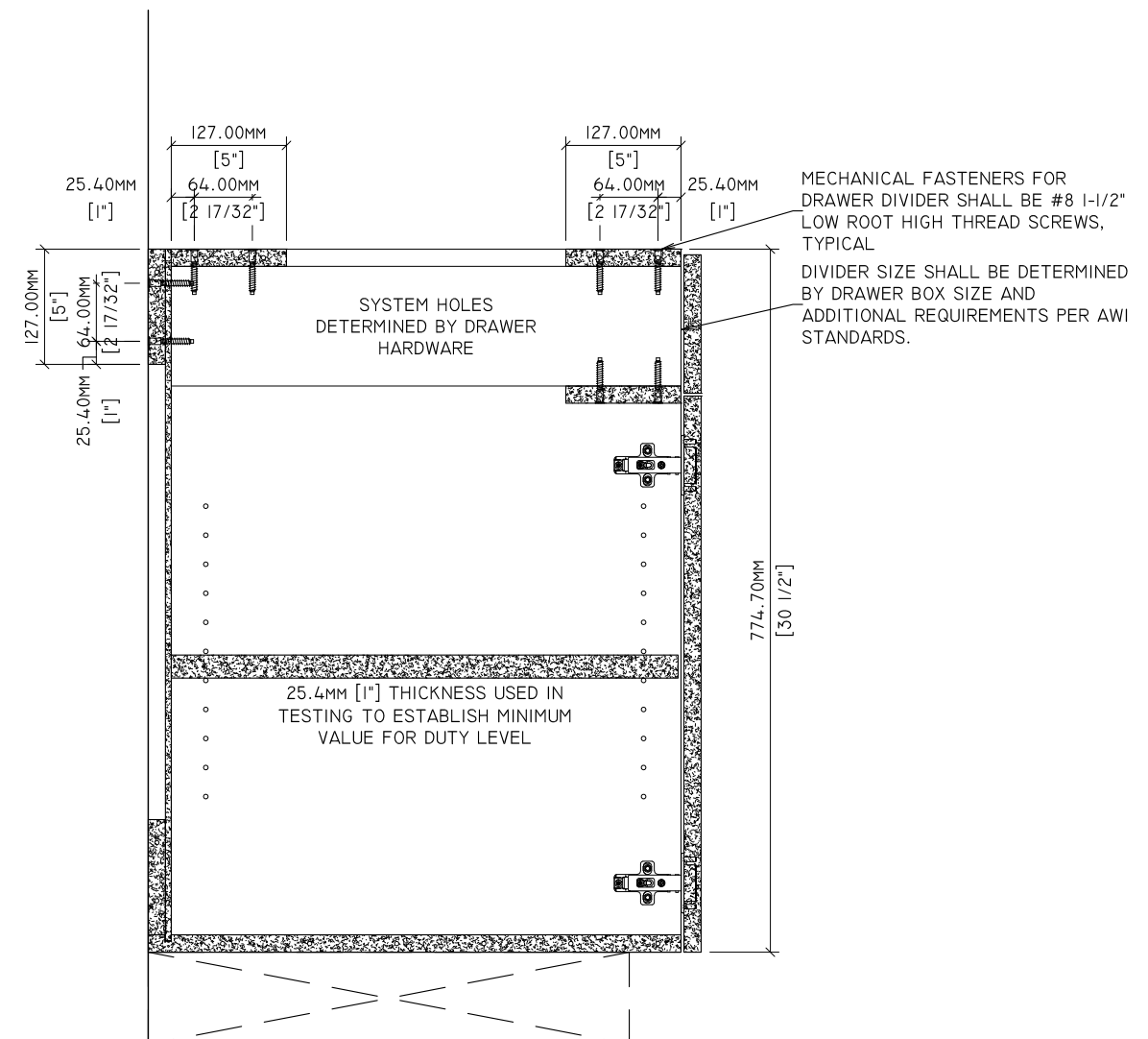

2 SECTION: DRAWER DIVIDER FASTENER LOCATIONS  
B-2.2 1-1/2" = 1'-0"

Drawn By:	HD	<b>REVISIONS</b>		SPECIMEN DWG. NO.: B-2.2
Reviewed By:	-	△1	-	JOINERY METHOD NO.: 7mm X 50mm CONFIRMAT
Revised By:	HKM	△2	7/7/2020	SPECIMEN MATERIAL: MDF, PB, VC
Revised By:	HKM	△3	7/9/2021	BATCH QUANTITY: -
Approved By:	-	△4	-	SCALE: AS NOTED

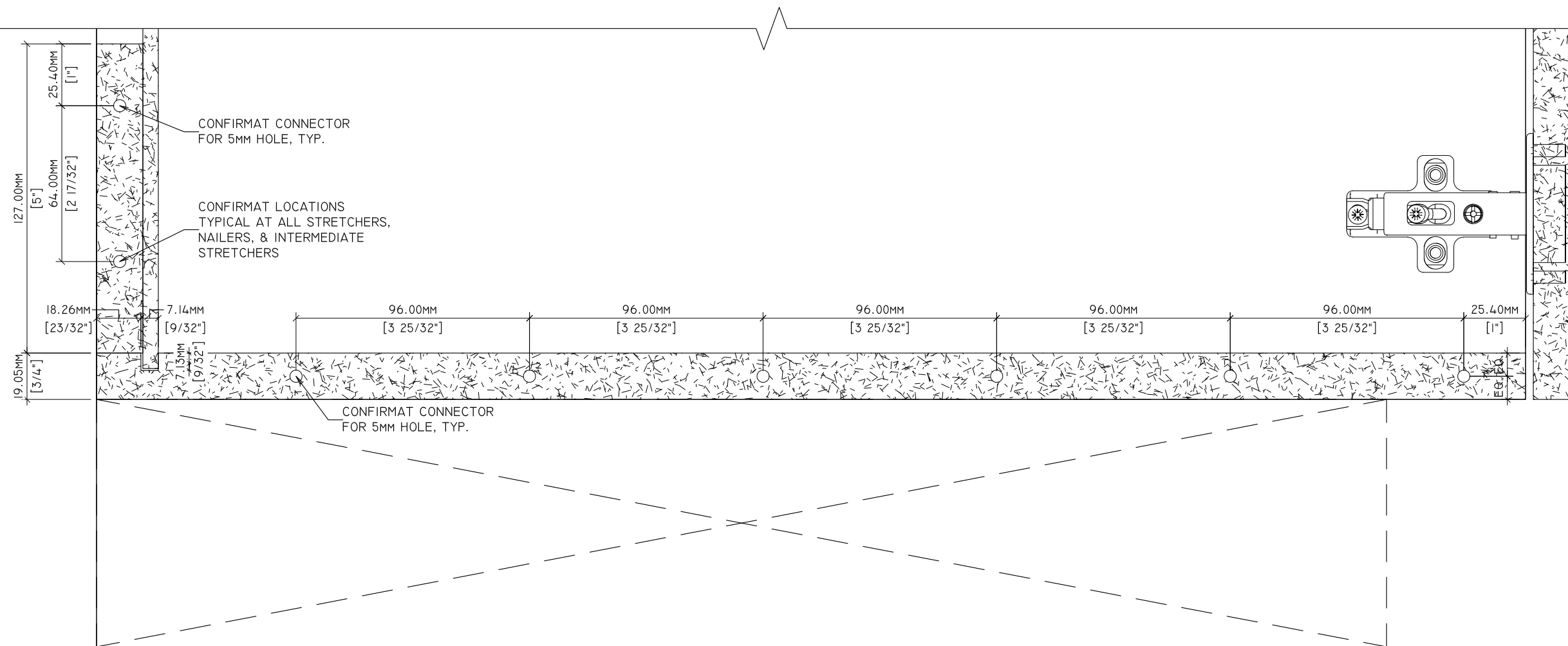

1  
B-2.3

DETAIL  
6" = 1'-0"



**Standards Development and Performance Testing**  
1310 Southerfield Road  
Americus, GA 31709

Drawn By:	HD	<b>REVISIONS</b>		SPECIMEN DWG. NO.: B-2.3
Reviewed By:	-	△1	-	JOINERY METHOD NO.: 7mm X 50mm CONFIRMAT
Revised By:	HKM	△2	7/7/2020	SPECIMEN MATERIAL: MDF, PB, VC
Revised By:	HKM	△3	7/9/2021	BATCH QUANTITY: -
Approved By:	-	△4	-	SCALE: AS NOTED

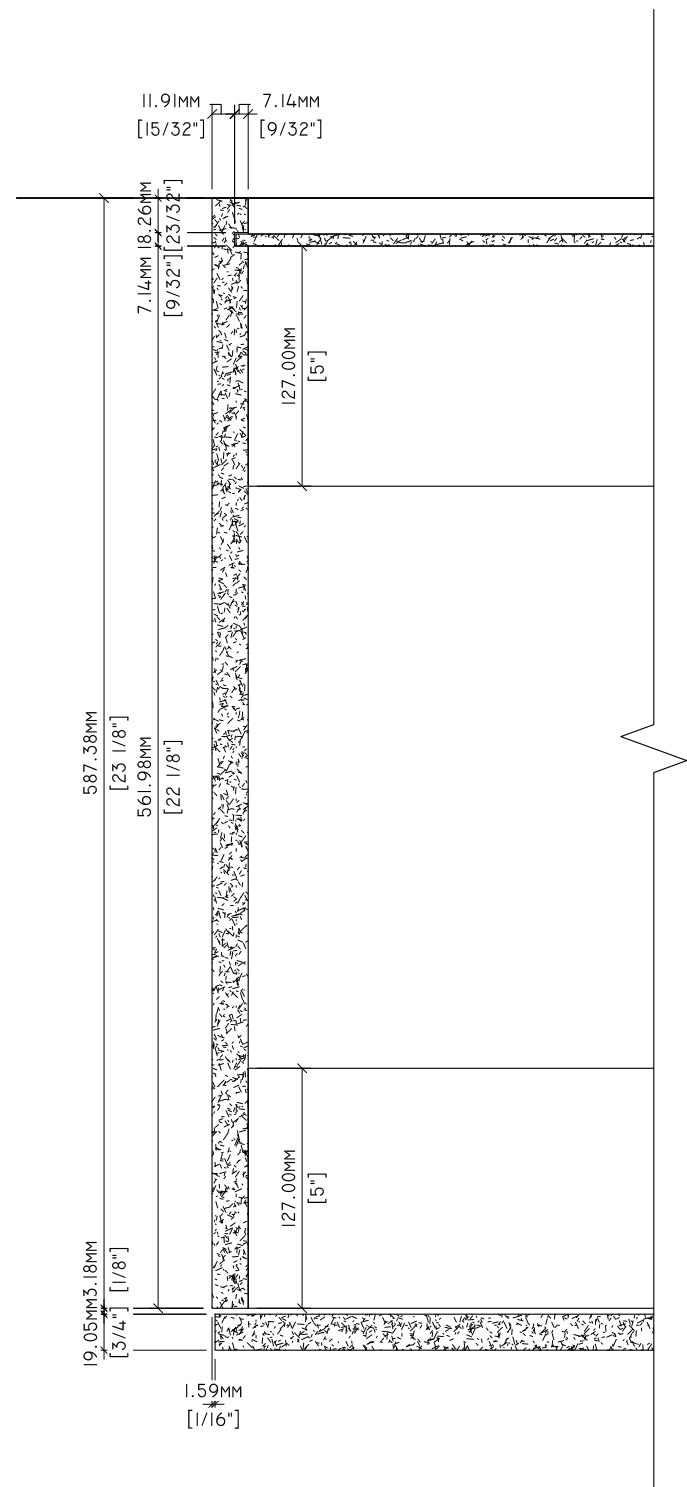

1 PLAN DETAIL  
B-2.4 3" = 1'-0"

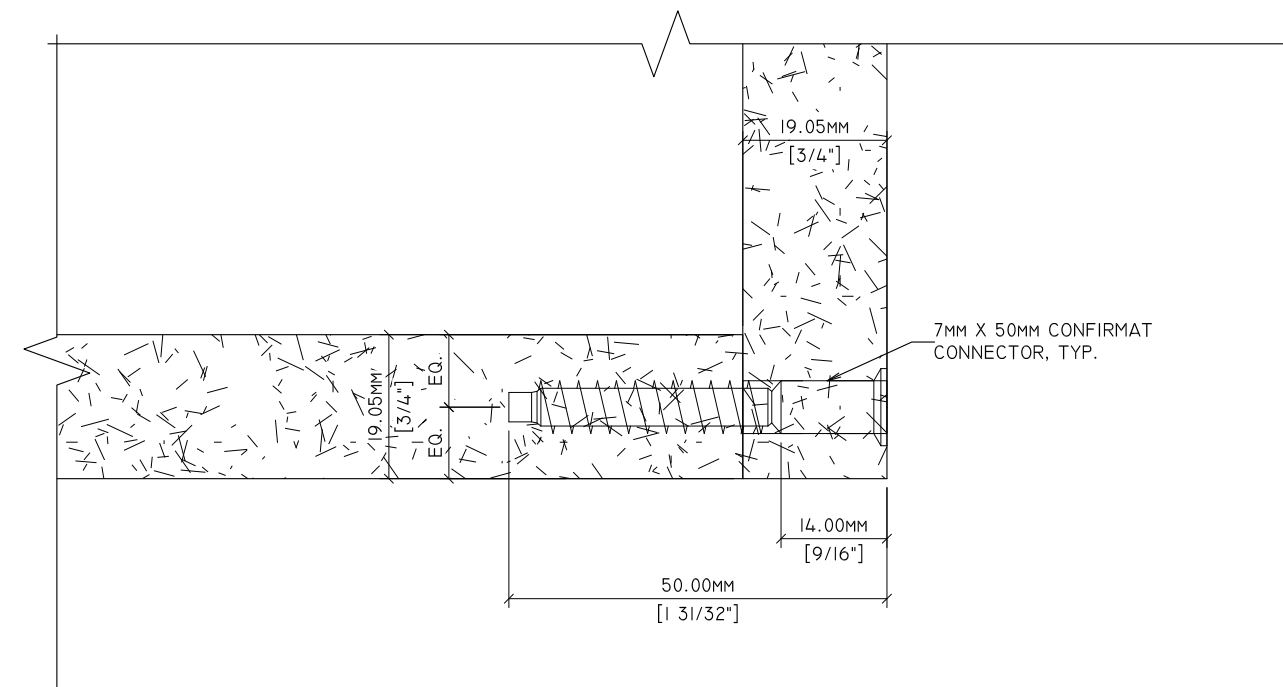

2 DETAIL  
B-2.4 12" = 1'-0"



**Standards Development and Performance Testing**  
1310 Southerfield Road  
Americus, GA 31709

Drawn By:	HD	<b>REVISIONS</b>		SPECIMEN DWG. NO.: B-2.4
Reviewed By:	-	△1	-	JOINERY METHOD NO.: 7mm X 50mm CONFIRMAT
Revised By:	HKM	△2	7/7/2020	SPECIMEN MATERIAL: MDF, PB, VC
Revised By:	HKM	△3	7/9/2021	BATCH QUANTITY: -
Approved By:	-	△4	-	SCALE: AS NOTED